



深圳市航昱微科技有限公司

SHENZHEN BLUESKY TECHNOLOGY CO.,LTD

SPECIFICATION FOR APPROVAL

承认书

Spec. No.: HYN4032-20210930

Issued Date: 2024-04-24

CUSTOMER:

客户

PART NAME: SMD Plastic NTC Varistors

名称 SMD塑封热敏电阻器

APPLICATION: Suppress Surge Cur

用途 抑制突破电流

PART NO.:

料号 HYN4032-202

UL FILE NO:

UL证书号

CUSTOMER PART NO.:

客户料号

客户承认 CUSTOMER CONFIRM

承认章 STAMP	核准 APPROVE	审核 CHECK	经办人 SIGNATURE

公司名称: 深圳市航昱微科技有限公司

SHENZHEN BLUESKY TECHNOLOGY CO.,LTD

公司地址: 深圳市福田区深南中路3027号嘉汇新城

汇商中心2918-2921室

电 话: 0755-83654115

传 真: 0755-83655503



深圳市航昱微科技有限公司

SHENZHEN BLUESKY TECHNOLOGY CO.,LTD

1、特点

1. 符合RoHS
2. 适用于表面安装技术回流焊及波峰焊
3. 结构小巧、节省空间
4. 强大的抑制浪涌电流能力
5. 包装材料满足UL94-V0

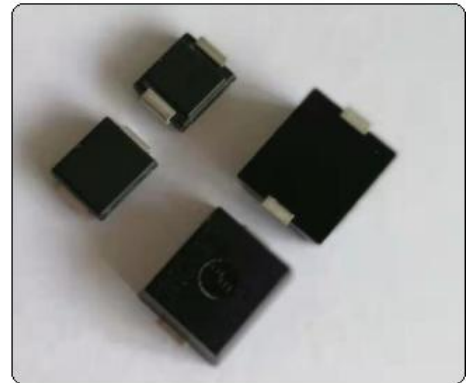

2、用途

1. 电源供应器
2. 家用电器
3. 工业设备
4. LED照明电源

3、编码规则

HY N -4032 - 20 2

1 2 3 4 5

1、HY:公司代码: 航昱微

2、N: 功率型负温度系数热敏电阻

3、尺寸: 用代码表示

尺寸	3225	3535	4032	6355
----	------	------	------	------

4、阻值: 如20 ~ 20 Ω

5、最大冲击电流: 如2 ~ 2A



深圳市航昱微科技有限公司

SHENZHEN BLUESKY TECHNOLOGY CO.,LTD

4. 外形尺寸 (Appearance)

4-1. 标志 Marking

HYN4032-202

4-2. 尺寸 Dimensional Drawing (mm)

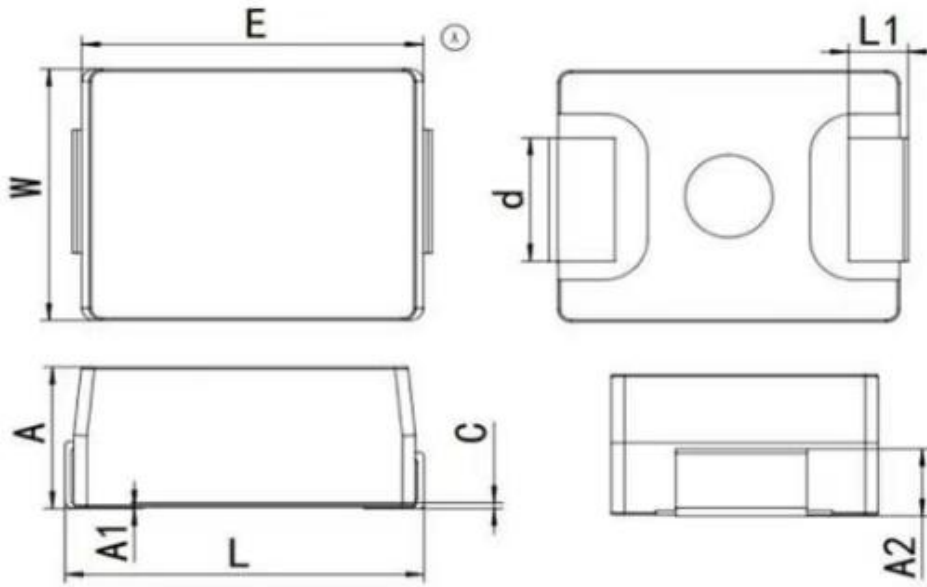

UNIT		E	W	A	L	A1	A2	d	L1	C
mm	max	10.5	8.5	4.1	11.5	0.22	2.6	3.2	1.9	0.22
	cen	10	8.0	3.8	11	0.2	2.2	3.0	1.6	0.2
	min	9.5	7.5	3.5	10.5	0.18	1.8	2.8	1.4	0.18

4-3. 材料 (Materials)

- ①封装材料 (Wrapper) : 热熔树脂 (Fusible Resin)
- ②引线 (Down-lead) : 镀锡铜线排型 (Tinned Copper Wire L-shape)
- ③颜色 (Coating color) : 黑色 (Black)



深圳市航昱微科技有限公司

SHENZHEN BLUESKY TECHNOLOGY CO.,LTD

4-4. 焊盘布局、尺寸 Recommended size of solder paste or size (mm)

项目(4032)	A	B	C
尺寸 (EIA)	3.5	2.8	6.5

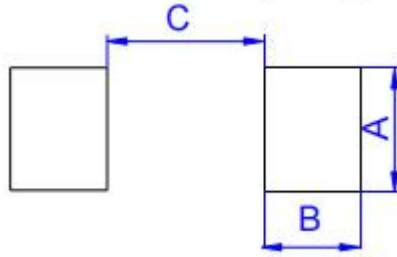



深圳市航昱微科技有限公司

SHENZHEN BLUESKY TECHNOLOGY CO.,LTD

5. 主要技术参数 (Parameters of Technology)

- ①25℃时零功率电阻值 (Ω) (Zero Power Resistance at 25℃) : 20±20%
- ②B 值25/50℃ (K) (B Value) : 2900±10%
- ③热时间常数(S) (Thermal Time Constant) : 46
- ④热耗散系数 (mW/℃) (Thermal Dissipation Constant) : 18
- ⑤工作温度 (℃) (Operating Temperature) : -40 - +150
- ⑥最大稳态电流(I_{max}/25℃) (Max Steady State Current) : 2A
- ⑦最大冲击电容量(μF/240V) (Max. Shock Capacity) : 220

6. 电气性能及要求 (electrical properties and requirements)

项目	测试方法	性能要求
零功率电阻值	在25℃下, 当由于电阻体内部发热引起的电阻值变化相对于总测量误差可以忽略不计时所测得的电阻值。	见电特性参数
B值	B值可以用25℃和50℃时的零功率电阻值计算出来。其计算公式是: $B = \frac{T_1 * T_2}{T_2 - T_1} * \ln \left(\frac{R_1}{R_2} \right)$	见电特性参数
热耗散系数	在规定的温度下, 热敏电阻中耗散的功率变化与热敏电阻相应温度变化之比。其单位: mw/℃	见电特性参数
热时间常数	在零功率条件下, 当温度发生变化时, 热敏电阻的温度变化为其初始的和最终的温度差的63.2%所需的时间。	见电特性参数
工作温度	热敏电阻器长期连续工作所允许的温度范围。	-40--+150℃
最大稳态电流	通电1000h后, 电流达到稳态时, 热敏电阻所承受的最大电流。	见电特性参数
稳态湿热	温度40±2℃, 相对湿度93±3%, 存放1000±2小时后, 在正常状态下1小时。	无可见损伤、标志清晰、无击穿或飞弧, 绝缘电阻大于100MΩ。电阻值的最大变化率在±15%以内。
耐电压	施加1200ACV电压, 时间60S, 电压加在电阻器引线及绝缘层之间	无击穿或飞弧
温度快速变化	-40℃/30 → 25℃/5 → +180℃/30 → 25℃/5	电阻变化率±20%



深圳市航昱微科技有限公司

SHENZHEN BLUESKY TECHNOLOGY CO.,LTD

7、推荐焊接条件

7-1波峰焊曲线

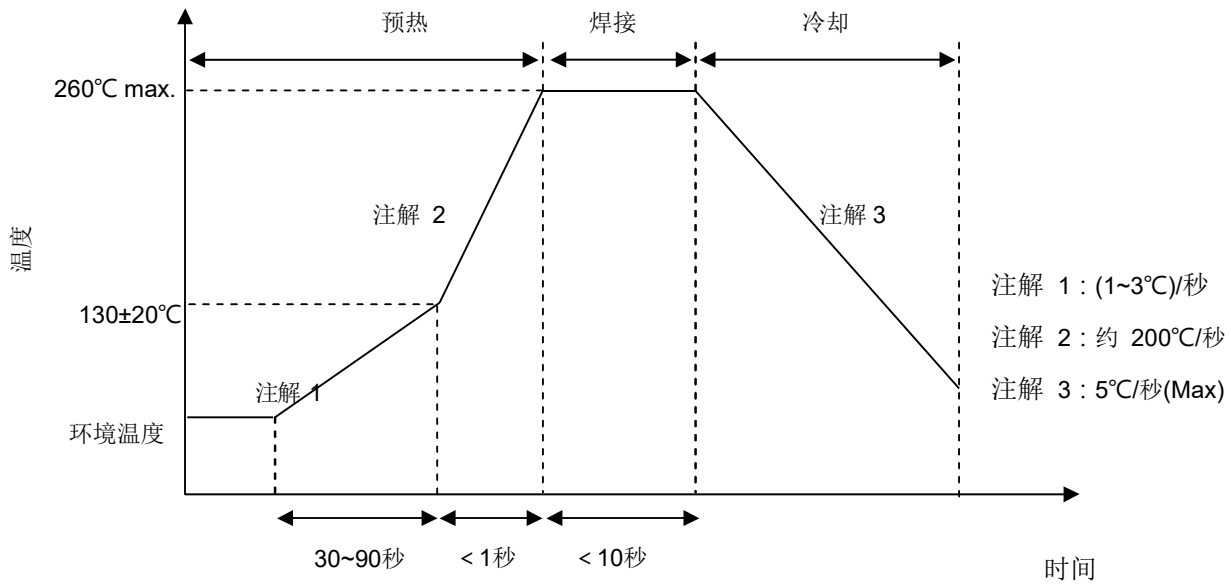

7-2回流焊曲线

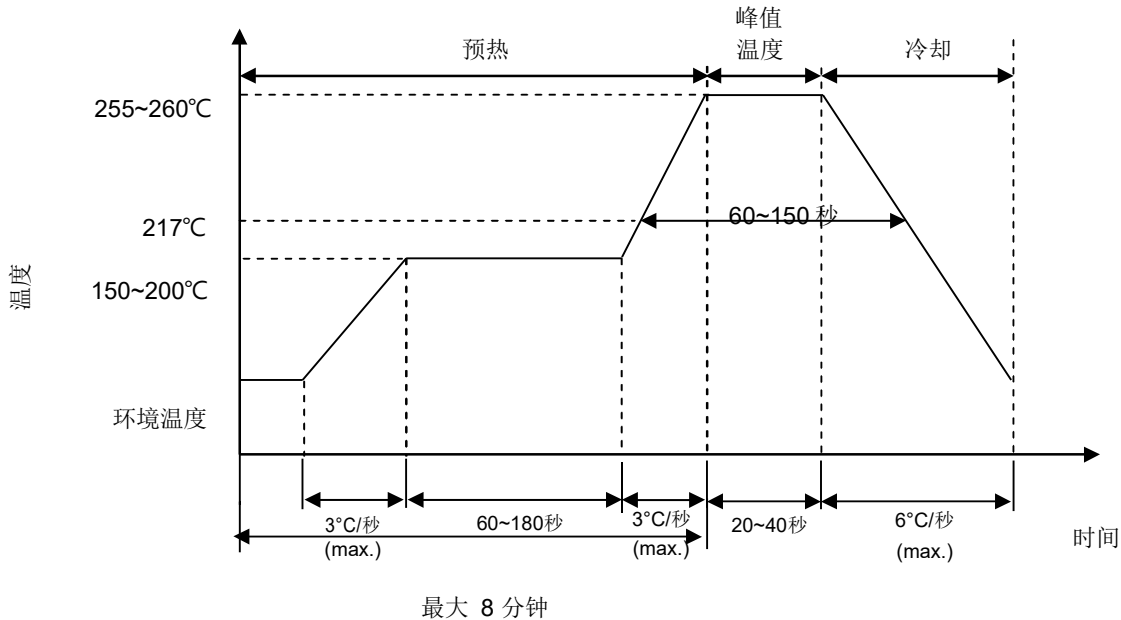

7-3烙铁重工焊接条件

项目	条件
烙铁头部温度	350°C (max.)
焊接时间	3 sec (max.)
烙铁头直径	Φ3 mm (max.)



深圳市航昱微科技有限公司

SHENZHEN BLUESKY TECHNOLOGY CO.,LTD

8. R-T表

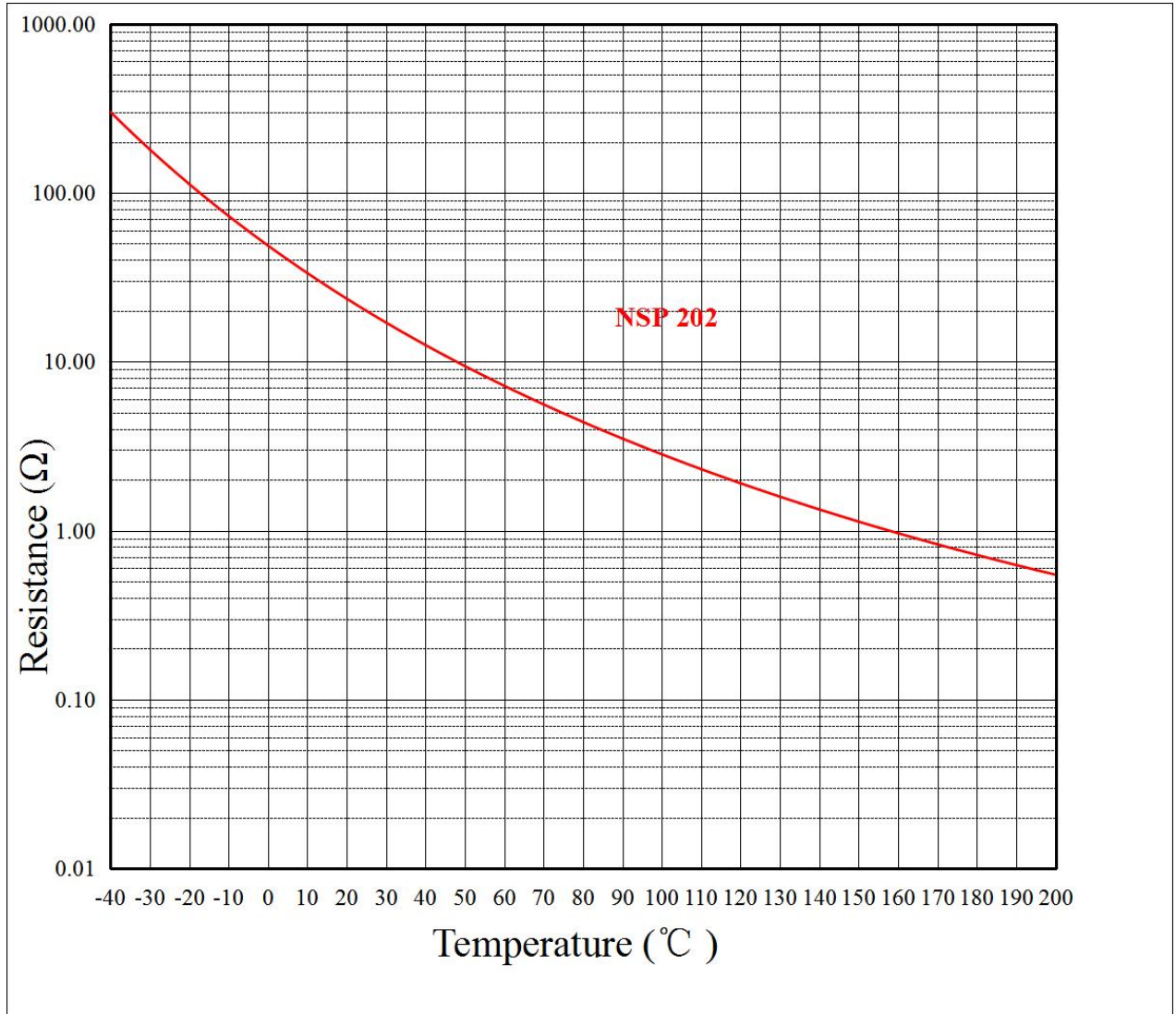



深圳市航昱微科技有限公司

SHENZHEN BLUESKY TECHNOLOGY CO.,LTD

型号:	HYN4032-202			R :	20	ohms ±	20%	
				B :	2900	° K ±	10%	
网址:	http://www.hywsmd.com/							
温度	阻值 (Ω)			温度系数	阻值精度偏差 (%)		测温精度偏差(°C)	
(°C)	下限值	中心值	上限值	(%/°C)	最小	最大	最小	最大
-40.0	87.6998	132.4361	191.9930	-1.86	-33.78	44.97	-24.23	18.20
-39.0	86.2171	129.9506	188.0332	-1.93	-33.65	44.70	-23.13	17.41
-38.0	84.7023	127.4162	184.0032	-2.01	-33.52	44.41	-22.14	16.71
-37.0	83.1604	124.8417	179.9176	-2.08	-33.39	44.12	-21.25	16.08
-36.0	81.5962	122.2353	175.7902	-2.14	-33.25	43.81	-20.44	15.51
-35.0	80.0143	119.6051	171.6338	-2.21	-33.10	43.50	-19.71	15.00
-34.0	78.4189	116.9583	167.4605	-2.27	-32.95	43.18	-19.04	14.53
-33.0	76.8141	114.3018	163.2814	-2.33	-32.80	42.85	-18.42	14.10
-32.0	75.2035	111.6421	159.1070	-2.38	-32.64	42.52	-17.85	13.70
-31.0	73.5908	108.9852	154.9467	-2.43	-32.48	42.17	-17.32	13.34
-30.0	71.9792	106.3365	150.8095	-2.49	-32.31	41.82	-16.83	13.00
-29.0	70.3716	103.7010	146.7032	-2.53	-32.14	41.47	-16.37	12.69
-28.0	68.7710	101.0836	142.6352	-2.58	-31.97	41.11	-15.94	12.39
-27.0	67.1798	98.4883	138.6121	-2.62	-31.79	40.74	-15.53	12.12
-26.0	65.6005	95.9190	134.6398	-2.66	-31.61	40.37	-15.15	11.87
-25.0	64.0351	93.3793	130.7235	-2.70	-31.42	39.99	-14.80	11.63
-24.0	62.4857	90.8721	126.8680	-2.74	-31.24	39.61	-14.46	11.40
-23.0	60.9539	88.4004	123.0773	-2.78	-31.05	39.23	-14.14	11.19
-22.0	59.4415	85.9665	119.3550	-2.81	-30.86	38.84	-13.83	10.99
-21.0	57.9497	83.5727	115.7042	-2.84	-30.66	38.45	-13.54	10.80
-20.0	56.4798	81.2207	112.1274	-2.87	-30.46	38.05	-13.26	10.62
-19.0	55.0329	78.9122	108.6268	-2.90	-30.26	37.66	-13.00	10.44
-18.0	53.6101	76.6486	105.2041	-2.92	-30.06	37.26	-12.74	10.28
-17.0	52.2121	74.4309	101.8607	-2.95	-29.85	36.85	-12.50	10.13
-16.0	50.8396	72.2601	98.5977	-2.97	-29.64	36.45	-12.27	9.98
-15.0	49.4931	70.1369	95.4156	-2.99	-29.43	36.04	-12.04	9.83
-14.0	48.1733	68.0619	92.3150	-3.01	-29.22	35.63	-11.83	9.70
-13.0	46.8804	66.0353	89.2960	-3.03	-29.01	35.22	-11.62	9.57
-12.0	45.6148	64.0574	86.3584	-3.05	-28.79	34.81	-11.42	9.44
-11.0	44.3765	62.1283	83.5019	-3.07	-28.57	34.40	-11.22	9.32
-10.0	43.1658	60.2478	80.7261	-3.08	-28.35	33.99	-11.03	9.20
-9.0	41.9827	58.4159	78.0301	-3.09	-28.13	33.58	-10.85	9.09
-8.0	40.8272	56.6321	75.4132	-3.11	-27.91	33.16	-10.67	8.98
-7.0	39.6991	54.8962	72.8744	-3.12	-27.68	32.75	-10.50	8.88
-6.0	38.5984	53.2076	70.4125	-3.13	-27.46	32.34	-10.33	8.77
-5.0	37.5249	51.5659	68.0263	-3.14	-27.23	31.92	-10.17	8.68
-4.0	36.4782	49.9703	65.7145	-3.15	-27.00	31.51	-10.01	8.58



深圳市航昱微科技有限公司

SHENZHEN BLUESKY TECHNOLOGY CO.,LTD

-3.0	35.4583	48.4203	63.4758	-3.15	-26.77	31.09	-9.86	8.49
-2.0	34.4646	46.9150	61.3086	-3.16	-26.54	30.68	-9.70	8.39
-1.0	33.4970	45.4537	59.2113	-3.17	-26.31	30.27	-9.56	8.31
0.0	32.5550	44.0357	57.1826	-3.17	-26.07	29.86	-9.41	8.22
1.0	31.6382	42.6600	55.2207	-3.18	-25.84	29.44	-9.27	8.14
2.0	30.7463	41.3259	53.3240	-3.18	-25.60	29.03	-9.13	8.05
3.0	29.8788	40.0323	51.4908	-3.18	-25.36	28.62	-9.00	7.97
4.0	29.0352	38.7785	49.7196	-3.18	-25.13	28.21	-8.86	7.89
5.0	28.2151	37.5634	48.0087	-3.18	-24.89	27.81	-8.73	7.82
6.0	27.4180	36.3862	46.3563	-3.18	-24.65	27.40	-8.61	7.74
7.0	26.6435	35.2459	44.7608	-3.18	-24.41	27.00	-8.48	7.67
8.0	25.8910	34.1416	43.2206	-3.18	-24.17	26.59	-8.36	7.59
9.0	25.1600	33.0723	41.7340	-3.18	-23.92	26.19	-8.23	7.52
10.0	24.4502	32.0372	40.2994	-3.18	-23.68	25.79	-8.11	7.45
11.0	23.7609	31.0352	38.9152	-3.18	-23.44	25.39	-7.99	7.38
12.0	23.0917	30.0656	37.5798	-3.17	-23.20	24.99	-7.88	7.31
13.0	22.4420	29.1272	36.2917	-3.17	-22.95	24.60	-7.76	7.24
14.0	21.8115	28.2194	35.0494	-3.16	-22.71	24.20	-7.65	7.18
15.0	21.1996	27.3411	33.8513	-3.16	-22.46	23.81	-7.54	7.11
16.0	20.6058	26.4915	32.6960	-3.15	-22.22	23.42	-7.43	7.04
17.0	20.0296	25.6697	31.5821	-3.15	-21.97	23.03	-7.32	6.98
18.0	19.4706	24.8750	30.5082	-3.14	-21.73	22.65	-7.21	6.91
19.0	18.9283	24.1063	29.4729	-3.14	-21.48	22.26	-7.10	6.85
20.0	18.4022	23.3631	28.4749	-3.13	-21.23	21.88	-6.99	6.79
21.0	17.8920	22.6444	27.5128	-3.12	-20.99	21.50	-6.89	6.73
22.0	17.3970	21.9495	26.5855	-3.11	-20.74	21.12	-6.79	6.66
23.0	16.9170	21.2776	25.6917	-3.10	-20.49	20.75	-6.68	6.60
24.0	16.4515	20.6280	24.8303	-3.10	-20.25	20.37	-6.58	6.54
25.0	16.0000	20.0000	24.0000	-3.09	-20.00	20.00	-6.48	6.48
26.0	15.4665	19.3928	23.3433	-3.08	-20.25	20.37	-6.62	6.58
27.0	14.9523	18.8059	22.7064	-3.07	-20.49	20.74	-6.76	6.68
28.0	14.4568	18.2384	22.0888	-3.06	-20.73	21.11	-6.90	6.78
29.0	13.9792	17.6898	21.4899	-3.05	-20.98	21.48	-7.05	6.88
30.0	13.5189	17.1594	20.9092	-3.04	-21.22	21.85	-7.19	6.98
31.0	13.0752	16.6467	20.3460	-3.03	-21.45	22.22	-7.34	7.08
32.0	12.6475	16.1510	19.7999	-3.02	-21.69	22.59	-7.49	7.19
33.0	12.2354	15.6718	19.2704	-3.01	-21.93	22.96	-7.64	7.29
34.0	11.8381	15.2084	18.7569	-3.00	-22.16	23.33	-7.79	7.40
35.0	11.4551	14.7605	18.2589	-2.98	-22.39	23.70	-7.94	7.50
36.0	11.0859	14.3274	17.7760	-2.97	-22.62	24.07	-8.10	7.61
37.0	10.7300	13.9086	17.3077	-2.96	-22.85	24.44	-8.25	7.72
38.0	10.3868	13.5036	16.8535	-2.95	-23.08	24.81	-8.41	7.83
39.0	10.0560	13.1121	16.4130	-2.94	-23.31	25.17	-8.57	7.94



深圳市航昱微科技有限公司

SHENZHEN BLUESKY TECHNOLOGY CO.,LTD

40.0	9.7370	12.7334	15.9858	-2.92	-23.53	25.54	-8.73	8.05
41.0	9.4294	12.3672	15.5714	-2.91	-23.75	25.91	-8.90	8.16
42.0	9.1328	12.0131	15.1695	-2.90	-23.98	26.28	-9.06	8.27
43.0	8.8468	11.6705	14.7797	-2.89	-24.20	26.64	-9.23	8.38
44.0	8.5709	11.3392	14.4015	-2.87	-24.41	27.01	-9.40	8.50
45.0	8.3048	11.0187	14.0346	-2.86	-24.63	27.37	-9.57	8.61
46.0	8.0481	10.7087	13.6787	-2.85	-24.84	27.74	-9.74	8.72
47.0	7.8005	10.4087	13.3334	-2.83	-25.06	28.10	-9.91	8.84
48.0	7.5616	10.1185	12.9984	-2.82	-25.27	28.46	-10.09	8.96
49.0	7.3311	9.8377	12.6733	-2.81	-25.48	28.82	-10.27	9.08
50.0	7.1087	9.5660	12.3578	-2.79	-25.69	29.18	-10.44	9.19
51.0	6.8940	9.3030	12.0516	-2.78	-25.89	29.55	-10.63	9.31
52.0	6.6869	9.0485	11.7545	-2.77	-26.10	29.91	-10.81	9.43
53.0	6.4869	8.8022	11.4661	-2.75	-26.30	30.26	-10.99	9.55
54.0	6.2939	8.5637	11.1862	-2.74	-26.51	30.62	-11.18	9.68
55.0	6.1075	8.3329	10.9144	-2.73	-26.71	30.98	-11.37	9.80
56.0	5.9276	8.1094	10.6506	-2.71	-26.91	31.34	-11.56	9.92
57.0	5.7538	7.8930	10.3945	-2.70	-27.10	31.69	-11.75	10.05
58.0	5.5860	7.6835	10.1458	-2.68	-27.30	32.05	-11.94	10.17
59.0	5.4239	7.4806	9.9043	-2.67	-27.49	32.40	-12.14	10.30
60.0	5.2674	7.2840	9.6698	-2.66	-27.69	32.75	-12.33	10.43
61.0	5.1161	7.0936	9.4420	-2.64	-27.88	33.11	-12.53	10.55
62.0	4.9700	6.9092	9.2208	-2.63	-28.07	33.46	-12.73	10.68
63.0	4.8288	6.7305	9.0059	-2.61	-28.25	33.81	-12.94	10.81
64.0	4.6924	6.5574	8.7972	-2.60	-28.44	34.16	-13.14	10.94
65.0	4.5605	6.3896	8.5943	-2.58	-28.63	34.50	-13.35	11.08
66.0	4.4330	6.2271	8.3973	-2.57	-28.81	34.85	-13.56	11.21
67.0	4.3098	6.0695	8.2058	-2.56	-28.99	35.20	-13.77	11.34
68.0	4.1906	5.9167	8.0197	-2.54	-29.17	35.54	-13.98	11.48
69.0	4.0754	5.7686	7.8388	-2.53	-29.35	35.89	-14.20	11.61
70.0	3.9639	5.6251	7.6630	-2.51	-29.53	36.23	-14.42	11.75
71.0	3.8562	5.4858	7.4921	-2.50	-29.71	36.57	-14.63	11.89
72.0	3.7519	5.3508	7.3259	-2.48	-29.88	36.91	-14.86	12.03
73.0	3.6510	5.2199	7.1644	-2.47	-30.06	37.25	-15.08	12.17
74.0	3.5534	5.0929	7.0073	-2.46	-30.23	37.59	-15.30	12.31
75.0	3.4590	4.9697	6.8546	-2.44	-30.40	37.93	-15.53	12.45
76.0	3.3676	4.8501	6.7060	-2.43	-30.57	38.26	-15.76	12.59
77.0	3.2791	4.7341	6.5615	-2.41	-30.74	38.60	-15.99	12.74
78.0	3.1934	4.6216	6.4209	-2.40	-30.90	38.93	-16.23	12.88
79.0	3.1105	4.5123	6.2841	-2.39	-31.07	39.27	-16.46	13.03
80.0	3.0302	4.4063	6.1511	-2.37	-31.23	39.60	-16.70	13.17
81.0	2.9524	4.3034	6.0216	-2.36	-31.39	39.93	-16.94	13.32
82.0	2.8771	4.2034	5.8956	-2.34	-31.55	40.26	-17.18	13.47



深圳市航昱微科技有限公司

SHENZHEN BLUESKY TECHNOLOGY CO.,LTD

83.0	2.8041	4.1064	5.7730	-2.33	-31.71	40.58	-17.43	13.62
84.0	2.7334	4.0122	5.6536	-2.31	-31.87	40.91	-17.68	13.77
85.0	2.6649	3.9206	5.5374	-2.30	-32.03	41.24	-17.93	13.92
86.0	2.5985	3.8318	5.4243	-2.29	-32.18	41.56	-18.18	14.08
87.0	2.5342	3.7454	5.3141	-2.27	-32.34	41.88	-18.43	14.23
88.0	2.4718	3.6615	5.2069	-2.26	-32.49	42.21	-18.69	14.39
89.0	2.4113	3.5800	5.1024	-2.24	-32.64	42.53	-18.95	14.54
90.0	2.3527	3.5008	5.0007	-2.23	-32.79	42.85	-19.21	14.70
91.0	2.2958	3.4238	4.9016	-2.22	-32.94	43.16	-19.47	14.86
92.0	2.2407	3.3489	4.8051	-2.20	-33.09	43.48	-19.73	15.02
93.0	2.1872	3.2762	4.7110	-2.19	-33.24	43.80	-20.00	15.18
94.0	2.1353	3.2054	4.6194	-2.18	-33.38	44.11	-20.27	15.34
95.0	2.0850	3.1367	4.5301	-2.16	-33.53	44.42	-20.55	15.51
96.0	2.0361	3.0698	4.4430	-2.15	-33.67	44.74	-20.82	15.67
97.0	1.9887	3.0047	4.3582	-2.14	-33.81	45.05	-21.10	15.84
98.0	1.9427	2.9414	4.2755	-2.12	-33.95	45.35	-21.38	16.00
99.0	1.8980	2.8799	4.1949	-2.11	-34.09	45.66	-21.66	16.17
100.0	1.8546	2.8200	4.1163	-2.09	-34.23	45.97	-21.94	16.34
101.0	1.8125	2.7617	4.0397	-2.08	-34.37	46.27	-22.23	16.51
102.0	1.7716	2.7050	3.9649	-2.07	-34.51	46.58	-22.52	16.68
103.0	1.7319	2.6498	3.8921	-2.05	-34.64	46.88	-22.81	16.86
104.0	1.6933	2.5961	3.8210	-2.04	-34.77	47.18	-23.11	17.03
105.0	1.6558	2.5438	3.7516	-2.03	-34.91	47.48	-23.41	17.21
106.0	1.6194	2.4929	3.6840	-2.02	-35.04	47.78	-23.71	17.38
107.0	1.5840	2.4433	3.6180	-2.00	-35.17	48.08	-24.01	17.56
108.0	1.5496	2.3950	3.5535	-1.99	-35.30	48.37	-24.31	17.74
109.0	1.5162	2.3480	3.4907	-1.98	-35.43	48.67	-24.62	17.92
110.0	1.4837	2.3022	3.4293	-1.96	-35.55	48.96	-24.93	18.10
111.0	1.4521	2.2576	3.3695	-1.95	-35.68	49.25	-25.24	18.29
112.0	1.4213	2.2141	3.3110	-1.94	-35.80	49.54	-25.56	18.47
113.0	1.3915	2.1717	3.2539	-1.93	-35.93	49.83	-25.88	18.66
114.0	1.3624	2.1304	3.1982	-1.91	-36.05	50.12	-26.20	18.85
115.0	1.3341	2.0902	3.1438	-1.90	-36.17	50.41	-26.52	19.03
116.0	1.3066	2.0510	3.0907	-1.89	-36.29	50.69	-26.85	19.22
117.0	1.2798	2.0128	3.0388	-1.88	-36.41	50.98	-27.18	19.42
118.0	1.2538	1.9755	2.9881	-1.86	-36.53	51.26	-27.51	19.61
119.0	1.2284	1.9391	2.9385	-1.85	-36.65	51.54	-27.85	19.80
120.0	1.2038	1.9037	2.8902	-1.84	-36.77	51.82	-28.19	20.00
121.0	1.1797	1.8691	2.8429	-1.83	-36.88	52.10	-28.53	20.20
122.0	1.1564	1.8354	2.7967	-1.81	-37.00	52.37	-28.87	20.39
123.0	1.1336	1.8025	2.7515	-1.80	-37.11	52.65	-29.22	20.59
124.0	1.1114	1.7704	2.7074	-1.79	-37.22	52.92	-29.57	20.79
125.0	1.0898	1.7391	2.6643	-1.78	-37.34	53.20	-29.92	21.00



深圳市航昱微科技有限公司

SHENZHEN BLUESKY TECHNOLOGY CO.,LTD

126.0	1.0688	1.7086	2.6221	-1.77	-37.45	53.47	-30.27	21.20
127.0	1.0483	1.6788	2.5809	-1.75	-37.56	53.74	-30.63	21.41
128.0	1.0283	1.6497	2.5406	-1.74	-37.67	54.01	-30.99	21.61
129.0	1.0088	1.6213	2.5012	-1.73	-37.77	54.28	-31.36	21.82
130.0	0.9899	1.5935	2.4627	-1.72	-37.88	54.54	-31.72	22.03
131.0	0.9714	1.5665	2.4250	-1.71	-37.99	54.81	-32.09	22.24
132.0	0.9534	1.5400	2.3881	-1.70	-38.09	55.07	-32.47	22.46
133.0	0.9358	1.5142	2.3521	-1.68	-38.20	55.33	-32.84	22.67
134.0	0.9187	1.4890	2.3168	-1.67	-38.30	55.59	-33.22	22.89
135.0	0.9020	1.4644	2.2823	-1.66	-38.40	55.85	-33.60	23.11
136.0	0.8857	1.4403	2.2485	-1.65	-38.51	56.11	-33.99	23.32
137.0	0.8698	1.4168	2.2155	-1.64	-38.61	56.37	-34.38	23.55
138.0	0.8543	1.3938	2.1831	-1.63	-38.71	56.63	-34.77	23.77
139.0	0.8392	1.3714	2.1515	-1.62	-38.81	56.88	-35.17	23.99
140.0	0.8245	1.3495	2.1205	-1.61	-38.91	57.13	-35.56	24.22
141.0	0.8101	1.3280	2.0901	-1.60	-39.00	57.38	-35.97	24.45
142.0	0.7960	1.3071	2.0604	-1.58	-39.10	57.64	-36.37	24.67
143.0	0.7823	1.2866	2.0314	-1.57	-39.20	57.88	-36.78	24.90
144.0	0.7689	1.2666	2.0029	-1.56	-39.29	58.13	-37.19	25.14
145.0	0.7559	1.2470	1.9750	-1.55	-39.39	58.38	-37.61	25.37
146.0	0.7431	1.2279	1.9477	-1.54	-39.48	58.62	-38.02	25.61
147.0	0.7307	1.2091	1.9209	-1.53	-39.57	58.87	-38.45	25.84
148.0	0.7185	1.1908	1.8947	-1.52	-39.66	59.11	-38.87	26.08
149.0	0.7066	1.1729	1.8691	-1.51	-39.76	59.35	-39.30	26.32
150.0	0.6950	1.1554	1.8439	-1.50	-39.85	59.59	-39.73	26.57
151.0	0.6837	1.1383	1.8193	-1.49	-39.94	59.83	-40.17	26.81
152.0	0.6726	1.1215	1.7951	-1.48	-40.03	60.07	-40.61	27.06
153.0	0.6618	1.1051	1.7715	-1.47	-40.11	60.30	-41.05	27.30
154.0	0.6512	1.0890	1.7483	-1.46	-40.20	60.54	-41.49	27.55
155.0	0.6409	1.0733	1.7256	-1.45	-40.29	60.77	-41.94	27.81
156.0	0.6308	1.0579	1.7033	-1.44	-40.37	61.00	-42.40	28.06
157.0	0.6209	1.0429	1.6815	-1.43	-40.46	61.24	-42.85	28.31
158.0	0.6113	1.0281	1.6600	-1.42	-40.54	61.47	-43.31	28.57
159.0	0.6018	1.0137	1.6390	-1.41	-40.63	61.69	-43.78	28.83
160.0	0.5926	0.9995	1.6185	-1.40	-40.71	61.92	-44.25	29.09
161.0	0.5836	0.9857	1.5983	-1.39	-40.79	62.15	-44.72	29.35
162.0	0.5748	0.9721	1.5785	-1.38	-40.88	62.37	-45.19	29.62
163.0	0.5661	0.9589	1.5591	-1.37	-40.96	62.60	-45.67	29.89
164.0	0.5577	0.9459	1.5400	-1.36	-41.04	62.82	-46.16	30.15
165.0	0.5494	0.9331	1.5213	-1.35	-41.12	63.04	-46.64	30.42
166.0	0.5414	0.9206	1.5030	-1.34	-41.20	63.26	-47.13	30.70
167.0	0.5334	0.9084	1.4850	-1.33	-41.28	63.48	-47.63	30.97



深圳市航昱微科技有限公司

SHENZHEN BLUESKY TECHNOLOGY CO.,LTD

168.0	0.5257	0.8964	1.4674	-1.32	-41.35	63.69	-48.13	31.25
169.0	0.5181	0.8847	1.4501	-1.31	-41.43	63.91	-48.63	31.53
170.0	0.5107	0.8732	1.4331	-1.31	-41.51	64.13	-49.14	31.81
171.0	0.5035	0.8619	1.4164	-1.30	-41.58	64.34	-49.65	32.09
172.0	0.4964	0.8508	1.4000	-1.29	-41.66	64.55	-50.16	32.37
173.0	0.4894	0.8400	1.3840	-1.28	-41.73	64.76	-50.68	32.66
174.0	0.4826	0.8293	1.3682	-1.27	-41.81	64.97	-51.20	32.95
175.0	0.4759	0.8189	1.3527	-1.26	-41.88	65.18	-51.73	33.24
176.0	0.4694	0.8087	1.3375	-1.25	-41.95	65.39	-52.26	33.53
177.0	0.4630	0.7987	1.3226	-1.24	-42.03	65.59	-52.80	33.83
178.0	0.4568	0.7889	1.3079	-1.23	-42.10	65.80	-53.34	34.12
179.0	0.4506	0.7792	1.2935	-1.23	-42.17	66.00	-53.88	34.42
180.0	0.4446	0.7698	1.2794	-1.22	-42.24	66.21	-54.43	34.73



深圳市航昱微科技有限公司

SHENZHEN BLUESKY TECHNOLOGY CO.,LTD

9. 包装

9-1 编带包装方式说明

载带尺寸

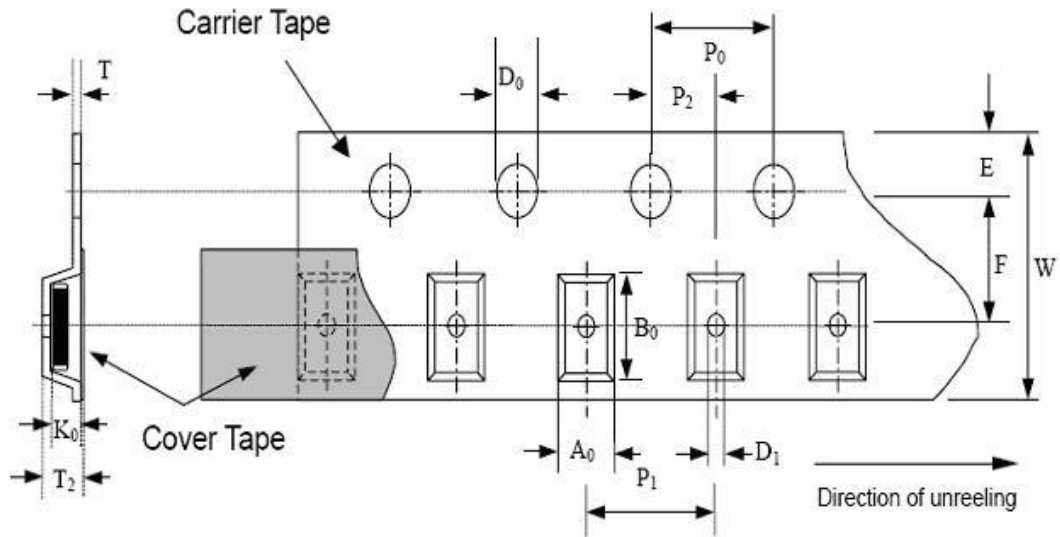

(单位 : mm)

type	A0	B0	K0	T	T2	D0	D1	P1	P2	P0	W	E	F
3220	7.0	8.7	3.85	0.3	5.50	1.55	1.55	12.00	2.00	4.00	16.00	1.75	7.5
4032	8.4	10.8	3.85	0.3	5.50	1.55	1.55	12.00	2.00	4.00	24.00	1.75	11.5
公差	±0.20	±0.20	±0.10	max	max	+0.05	±0.05	±0.10	±0.05	±0.1	±0.30	±0.10	±0.05

9-2 数量: 1000 (pcs)

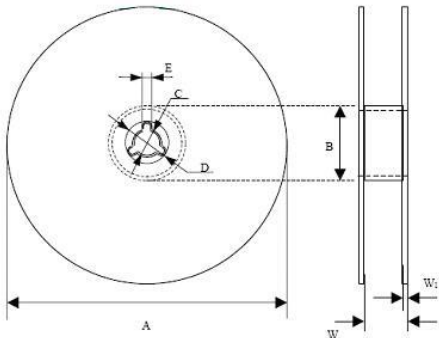

type	A	B	C	D	E	W	W1
4032	330.0±1.0	60.0±0.5	13.0±0.2	21.0±0.2	2.0±0.5	24.0±0.3	2.3±0.15



深圳市航昱微科技有限公司

SHENZHEN BLUESKY TECHNOLOGY CO.,LTD

(单位：mm)

10. 仓库存储条件

10-1 存储条件：

· 储存温度：-10℃~+45℃

相对湿度：≦75%RH

不要将本产品存放在有腐蚀性气体或是阳光直接照射的环境中保管。

10-2 存储期限：1年
